

Specification-grade landscape lighting, wet-location luminaire for step lighting or path lighting applications.

- Machined aluminum, available in seven standard TGIC powder coat finishes and clear anodized finish.
- Machined brass available in two finishes.
- Adjustable LED Module: 2W, 4W, 6W, 9W (12W startup draw)
- CRI = 85
- Available in 2700K, 3000K, 4000K
- Remote magnetic transformer required.
- Not compatible with electronic transformers.
- Stainless steel hardware.
- GY 6.35 bi-pin socket
- Tempered crystalline spread lens.
- 6 feet of 16/2 low voltage cable supplied.
- Mounting hardware not supplied.
- Core drill design for masonry (2 1/2" hole required).
- High-temperature silicone O-ring seal used to seal the cap against the body.
- Molded silicone wire pass-thru attached to socket wire prevents wicking and water leaking into the lamp compartment.
- Listed for wet location use.
- Warranty: Aluminum: 10 Years, Brass: 25 Years.

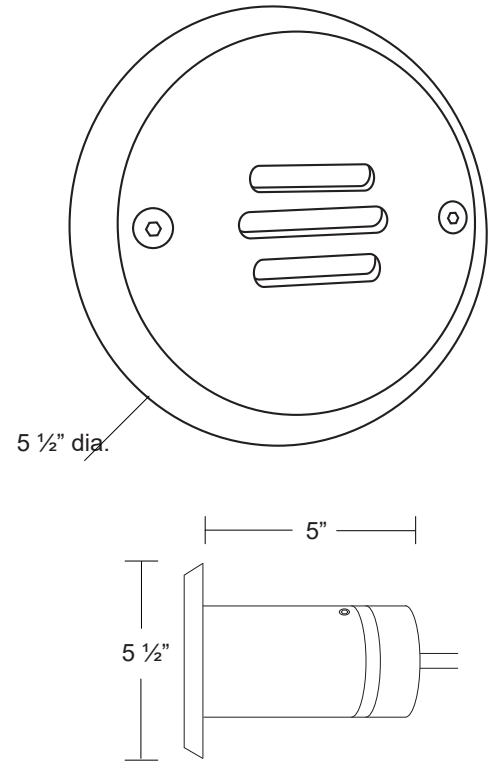

Specifications

MODEL: ST-4L  
 MATERIAL: Aluminum or Brass  
 VOLTAGE: 12V  
 WATTAGE: 2W, 4W, 6W, 9W  
 SOCKET: GY 6.35 Bi-pin porcelain socket rated 600V, 250°C 18 ga, Teflon® coated leads.

LAMPING: 9W LED Module ( 12W startup draw )

Wattage	2700k	3000K	4000K
2W	165 lms	190 lms	210 lms
4W	345 lms.	360 lms.	385 lms
6W	515 lms.	530 lms.	590 lms
9W	720 lms.	800 lms.	860 lms

Ordering Logic:

MODEL	METAL	FINISH	
ST - 4L	A - Aluminum B - Brass	BK - Black BZ - Bronze WT - White BG - Beige NT - Natural	BKT - Black Texture BZT - Bronze Texture SL - Silver AC - Aged Copper DB - Dark Brass

ORDERING EXAMPLE: ST - 4L - A - BK - 55\*

\*See Module sheet to select module type to be installed.

Excelsior Lighting, Inc.

PROJECT

TYPE

9W MULTI-LEVEL - 2W, 4W, 6W, 9W (165-860 Lumens)



- Equivalent to MR16 20W/35W/50W/75W Halogen (equivalent CBCP)
- Four light levels, 2700K, 3000K, or 4000K
- 10.8-13.2V AC/DC
- 12W startup draw
- Interchangeable lenses: 15°, 30°, 45°, 60°
- Superior Light Output and thermal performance compared to LED Replacement Lamps
- Compatible with low-voltage magnetic transformers
- L70=60,000 hours
- 3 Year warranty
- FCC Compliant
- RoHS Compliant
- Pb Free
- Field Replaceable

#	Specifications	Lumens
50	2W - 9W, 2700K, 15°	165-720
51	2W - 9W, 2700K, 30°	165-720
52	2W - 9W, 2700K, 45°	165-720
60	2W - 9W, 2700K, 60°	165-720
53	2W - 9W, 3000K, 15°	190-800
54	2W - 9W, 3000K, 30°	190-800
55	2W - 9W, 3000K, 45°	190-800
61	2W - 9W, 3000K, 60°	190-800
62	2W - 9W, 4000K, 15°	210-860
63	2W - 9W, 4000K, 30°	210-860
64	2W - 9W, 4000K, 45°	210-860
65	2W - 9W, 4000K, 60°	210-860

Wattage	2700k	3000K	4000K
2W	165 lms	190 lms	210 lms
4W	345 lms.	360 lms.	385 lms
6W	515 lms.	530 lms.	590 lms
9W	720 lms.	800 lms.	860 lms

LENSES INCLUDED

15°



45°



30°



60°

